

2

1

Aztec Aussie Connector 90mm SW Black

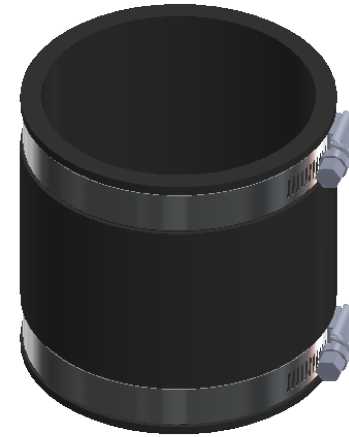
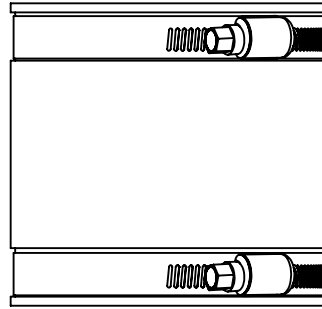
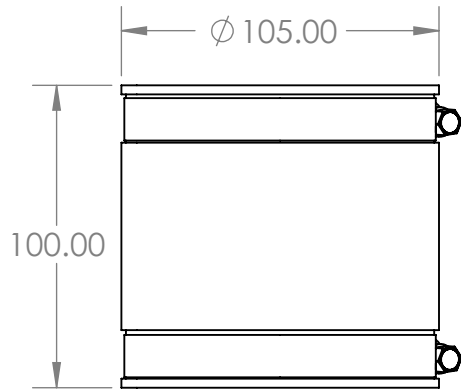

Description

- Available in two colour options, black or grey.
- Certified to AS/NZS 4327-1995.
- Suitable for low pressure drainage systems.
- Suits multiple pipe materials.
- Below and above ground applications.
- 316 stainless steel bands.
- Temperature range 38c continuous - 60c intermittently.

B

B

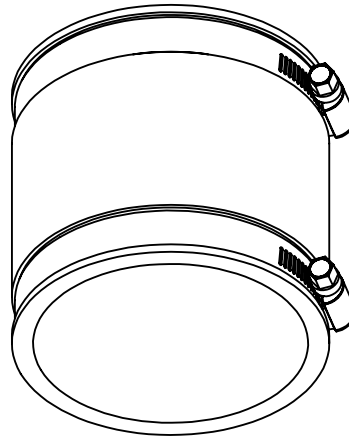
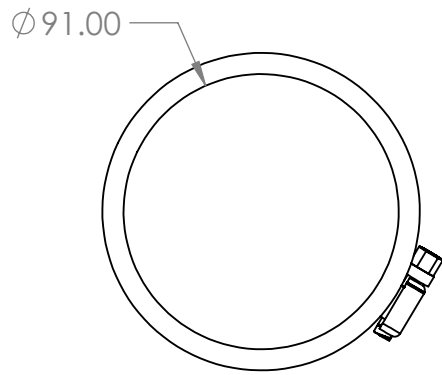

Q&A

Q. What is the use of the flexible connector?

A. For the joining of applications of pipes below and above ground. Flexible connectors are suitable for low pressure drainage systems.

Q. What is Aztec's Aussie Connectors pipe range?

A. 32mm - 300mm

Q. Are these suitable to potable water?

A. Testing is not a requirement under the current watermark certificate. Aussie Connectors are not advised to be used on potable waterlines.

Q. What is the pipe suitability?

A. PVC, Copper, Galvanised Steel, Cast Iron.

A

A



PROPRIETARY AND CONFIDENTIAL

THE INFORMATION CONTAINED IN THIS DRAWING IS THE SOLE PROPERTY OF AZTEC AUSTRALASIA. ANY REPRODUCTION IN PART OR AS A WHOLE WITHOUT THE WRITTEN PERMISSION OF AZTEC AUSTRALASIA IS PROHIBITED.

		UNLESS OTHERWISE SPECIFIED:		NAME	DATE		
		DIMENSIONS ARE IN INCHES TOLERANCES: FRACTIONAL \pm ANGULAR: MACH \pm BEND \pm TWO PLACE DECIMAL \pm THREE PLACE DECIMAL \pm		DRAWN		TITLE:	
		INTERPRET GEOMETRIC TOLERANCING PER:		CHECKED			
		MATERIAL		ENG APPR.			
NEXT ASSY	USED ON	FINISH		MFG APPR.			
APPLICATION		DO NOT SCALE DRAWING		Q.A.			
				COMMENTS:			
		SIZE	DWG. NO.			REV	
		A	AC090SWB				
		SCALE: 1:5	WEIGHT:			SHEET 1 OF 1	

2

1